

Starrett®



OPTICAL COMPARATORS

HDV300

HE400

HB400

HD400

HF600

HF750

VB400

VF600

METROLOGY  SOLUTIONS

STARRETT OPTICAL COMPARATORS

RUGGED, ACCURATE & EASY TO USE

Starrett optical comparators provide a time-tested, cost-effective solution for non-contact measurement. In this easy-to-learn technology, the image of a part is projected on a screen at a precisely known magnification. Measurements can then be taken off the image by moving the system's X-Y stage, or the image can simply be compared to a transparent overlay.

Our optical comparators combine mechanical stability with precision optics and versatile lighting to produce bright, sharp images and exceptional accuracy. We offer models in different sizes, with horizontal or vertical projection, lenses for magnifications from 5X to 100X, fiber-optic or video edge detection, manual, motor-driven or CNC workstage travel, and choice of digital readouts and PCs. Our proven mechanical designs are now enhanced with the latest metrology software for unmatched flexibility and productivity.

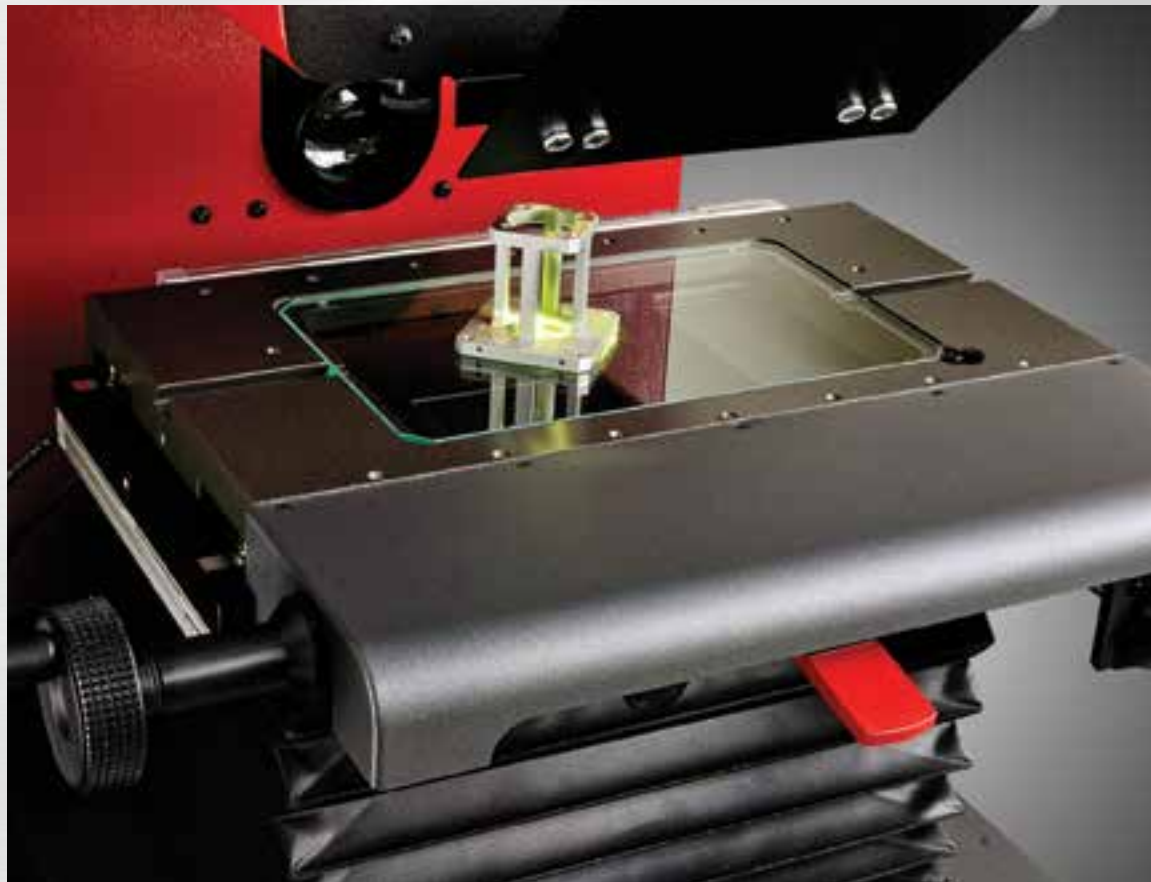

VERTICAL BENCHTOP OPTICAL PROJECTOR

The VB400 vertical projection comparator allows flat parts to be simply laid on a glass insert in the workstage. Features include a 16" diameter vertical screen, ultra-bright LEDs for long-life illumination, linear encoder scales for 0.00002" (0.5µm) resolution, and angle readout to 1 minute resolution. Available with stages with 8"x4" or 10"x6" of travel. Options include six projection lenses from 10X to 100X and a choice of digital interfaces.

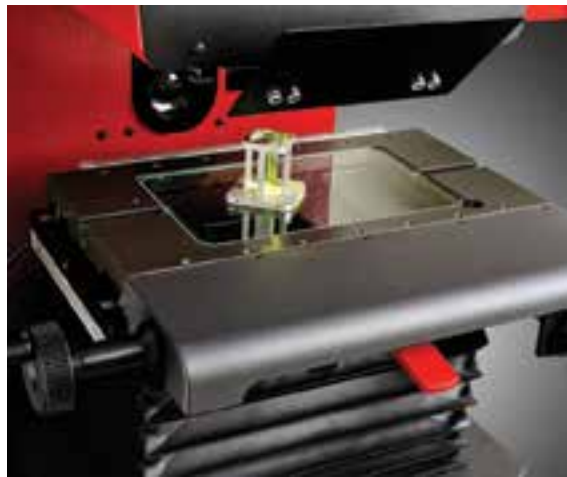

FEATURES

- 16" (400mm) diameter screen with crosslines, calibration marks and hood
- 16" x 9" (400x230mm) workstage with 8"x4" (200x100mm) of travel, 2" (50mm) focus travel
- 22lb (10kg) maximum load capacity
- Easy-to-use manual motion control
- Bayonet lens socket for quick magnification changes
- Dual mirror design for vertically correct image
- All metal construction for optimum stability
- Fine adjustment for X and Y axes
- Fast traverse, zero backlash mechanism for X-axis
- Heidenhain glass scales for 0.00002" (0.5µm) X and Y resolution
- Helix angle adjustment with ±15° Vernier scale
- LED profile illumination
- LED surface illumination using a beam-splitting mirror

OPTIONS

- 10X, 20X, 25X, 31.25X, 50X, 100X projection lenses
- Larger 18"x11" (450 x 285 mm) workstage with 10"x6" (250x150 mm) of travel
- Fiber-optic edge detection
- Choice of Quadra-Chek digital readouts, tablet computer with MetLogix M2 software, or all-in-one touch-screen computer with MetLogix M3 software
- 23" (58cm) or 32" (81cm) cabinet stand

MetLogix M2 Software on tablet PC with, color touch-screen (10"), 2D geometry software for point, line, circle, distance, angle and skew. Windows® 7 operating system and Wi-Fi network connectivity for import/export of CAD files and data. Supports optical edge detection and CNC control.

Quadra-Chek QC221/ND1203 Digital Readout. Monochrome LCD screen (5.7"), sealed metal housing, 2D geometry software. Supports optical edge detection.



Left to Right
Quadra-Chek QC321
MetLogix M2 10" tablet

FEATURE	METLOGIX M2	QUADRA-CHEK QC221
Mounted to comparator arm	x	x
Color graphics	x	
Touch-screen operation	x	
MS Windows operating system	x	
X-Y-Q (angle) measurements	x	x
2D geometry software w/ skew	x	x
Optical edge detection option	x	x
Video edge detection option		
CAD file import & export option	x	
CNC drive option	x	
Software developer	MetLogix	Metronics / Heidenhain

VB400 DIMENSIONS

Shipping weight: 443lbs (201kg)

Net weight: 423lbs (192kg)

Shipping dimensions:
48.8"x32.6"x34.6" (124x83x88cm).

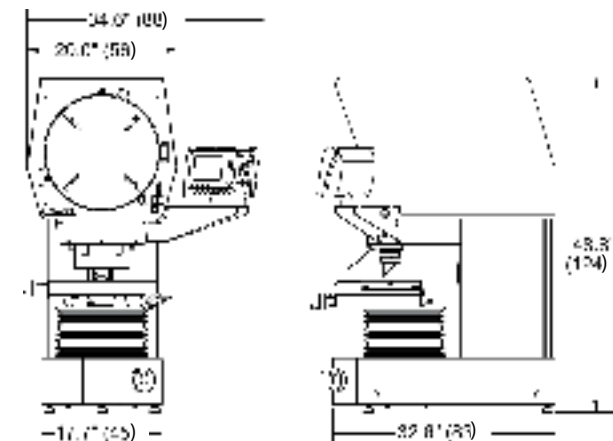

VB400 OPTICS

The VB400 is available with a choice of six projection lenses, which are mounted by a bayonet fitting for quick changeover between magnifications. Projected images are vertically correct.

LENS SELECTION GUIDE

MAGNIFICATION	10	20	25	31.25	50	100
Screen diameter	16" (400mm)					
Field of View	1.6" (40mm)	.8" (20mm)	.6" (16mm)	.5" (13mm)	.3" (8mm)	.16" (4mm)
Working Distance	3.1" (80mm)	3" (76mm)	2.5" (62mm)	2.2" (57mm)	2" (50mm)	1.5" (41mm)
Half Field View	5.5" (140mm)					4" (106mm)
Full Field View	5.5" (140mm)			5.4" (138mm)	5" (125mm)	3.9" (98mm)
Projected Image	Vertically Correct					

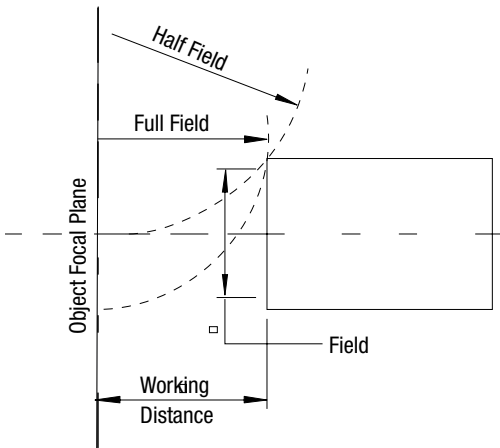







FIELD OF VIEW TERMINOLOGY

Working Distance:	Is the distance between the objective lens and the component when the component is in focus
Field Of View (FOV):	Is the viewable area. To fill the 16" (400 mm) diameter screen when using a 10x lens, the maximum diameter object projected would be 1.6" (40 mm).
Half Field View:	Is the maximum size a component can be projected to the center of the screen before colliding with the lens.
Full Field of View:	Is the maximum size a component can be projected over the full screen before colliding with the lens.
Projected Image:	Is how a component is projected onto the screen in relation to its placement on the workstage.

ACCESSORIES

Starrett manufactures a comprehensive range of fixtures and accessories for our line of optical comparators. Each accessory is made from the highest material and is machined, assembled and inspected to the same stringent quality standards as the comparator itself.

ACCESSORIES			
Precision Centers and Vees 	Rotary Vee Blocks 	Rotary Visers 	Cabinet Stands 
Vertical Glass Plate Holders 	Magnification Check Gradules 	Fixed Visers 	

Starrett Metrology Division

Starrett Kinematic Engineering, Inc.
26052-103 Merit Circle
Laguna Hills, CA USA 92653
Tel: 949-348-1213



Starrett.com

VB400

Bulletin 965
1.5M/Q 8/12

The L.S. Starrett Company 2012®
Specifications Subject to Change